



*einfach stark.*



**Smart** Grid Systems



- Products** Smart grid and peak-shave units
- Organisation** Flexible and customer oriented
- Employees** Well trained and dedicated
- Industry** Renewable Energy
- Locations** Germany, The Netherlands & Czech Republic

## Peak Shaving

Peak shaving is a technique whereby power spikes due to high currents drawn by machines are delivered by external equipment and not drawn from the main power source. In the general industry, power demand peaks usually are seen when equipment and machines are started in the morning or at the beginning of a work shift.

High frequency peak shaving needs a totally different approach since the wear and tear on the peak shaving system will be proportional to the frequency. If the high frequency is combined with high voltages and high currents, several other parameters come into play as well.

### Purposes of peak shaving

The main purposes of peak shaving can be divided into two issues:

#### Cost savings

- Many electricity companies charge extra if a certain power-limit has been reached and these charges can be considerable. The reasoning behind this is that these electricity companies have to ensure that the power is available at all times, so both generation and distribution should be able to deliver these relatively short peaks.
- In case of self-generated (solar-, wind-, diesel generator, etc.) electricity these sources should be over-dimensioned

to enable undisturbed delivery of short power peaks. Again, this means that the system is bigger than required for the average power use.

### Increased availability

- For some applications the electricity companies cannot guarantee the uninterrupted availability of power when high peaks are required but they are able to deliver the average power needed. In those cases, the option exists to either increase the available power from the mains network or to add a peak shaving unit. Obviously the first option can be very expensive and will take a long time.
- In applications where a power failure can have a major impact, a well-designed peak shaving system can also allow a continuation of work for some time. Thereby crucial steps in a production process can be finished, equipment can be placed in a safe position and resume of work will be easier once power is available again.

### Mixed mode systems

In most environments, the number of peaks is limited to only 2 or 3 per day. In reality this can be significantly less but the economics might still fit if the surcharge from the electricity company is high enough.

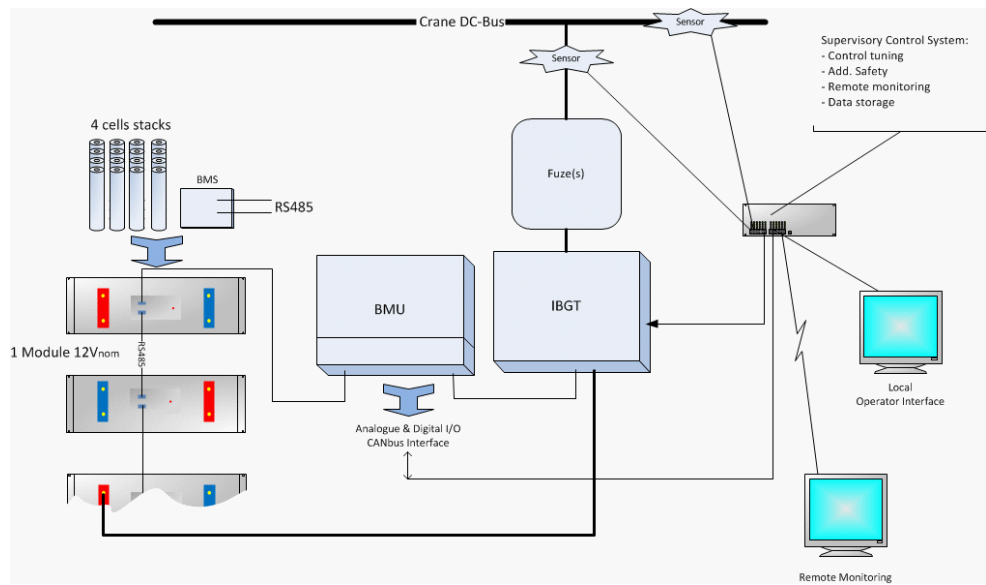

Typical system layout

In environments where the electricity is generated locally, since the BSOL-RED peak shaving system can work as a storage device too. Mixed mode systems are few and far between since most other systems have either high capacity but are unable to deliver high power or have a small capacity but are able to deliver high currents for a short period of time.

The BSOL RED system combines the best of both worlds and can be configured to suit your needs for capacity and power.



# smart(er) grids with peak-shaving and energy storage

## System Components

**BATTERIES:** The purpose build, high power Li-Fe batteries are designed for optimal cycle-life. By optimizing the Depth of Discharge (DoD) they can give 100.000's of cycles. Each battery unit has his own controller for safe and worry-free operation. This controller also connects the batteries to the application's DC-bus and optional DC/AC converter.

**SUPER CAPACITORS:** Depending on the application, additional super capacitors can be used to even further assist in the peak shaving and capture of any regenerative energy. These super capacitors also have their own controller.

**MONITORING:** Local and remote monitoring are used for system settings, monitoring and service. Remote systems can be permanently connected or polled on a set basis and data logging ensures that system variables and parameters are stored for later analysis.

**BENEFITS:** The integrated design of the peak shaving system, delivered completely in a purpose build container, enables quick installation with minimal impact on the existing application.

The high power available will take care of any peaks drawn by the application resulting in:

- Increased reliability of the power system
- Strong reduction of operational cost.
- Smaller solar- and wind energy system
- Lower maintenance cost for diesel generators.
- Reduced CO<sub>2</sub> for diesel generator operated plants
- Lower emission of dust particles

Furthermore:

- Units up to 1200Vdc and virtually no limit in capacity
- Remote monitoring and service against equipment loss during power outages.

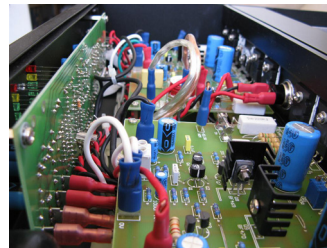

BMS unit

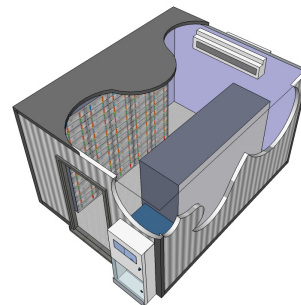

Stand-alone containerized unit

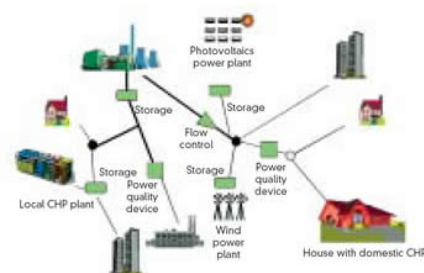

*Peak Shaving was long an area where the only focus was reduction of operational cost. Today's issues has added factors; the reduction of CO<sub>2</sub> emmission, the increased availability of power and the storage of locally generated electricity.*

## CURRENT PROJECTS

APPLICATION	CAPACITY	LOCATION	NOTES
Peak Shaving Unit	1,1MW	Amsterdam	Floating Crane System
Peak Shaving Unit	2,1MW	Colombia	Crane System
Grid Support Unit	2,1MW	St. Petersburg	Steel works
Peak Shaving Unit	1,1MW	Le Havre	Crane System
Peak Shaving Unit	1,6MW	Jakarta	Crane System



## Smart(er) Grid Solutions

Siemensstrasse 13, 40789 Monheim, Germany  
Tel +49 (0)2173 330330 Fax +49 (0)2173 330333  
Web: [www.bsol-red.eu](http://www.bsol-red.eu) Email: [info@bsol.de](mailto:info@bsol.de)